

## SPLINE GAGE HANDLES

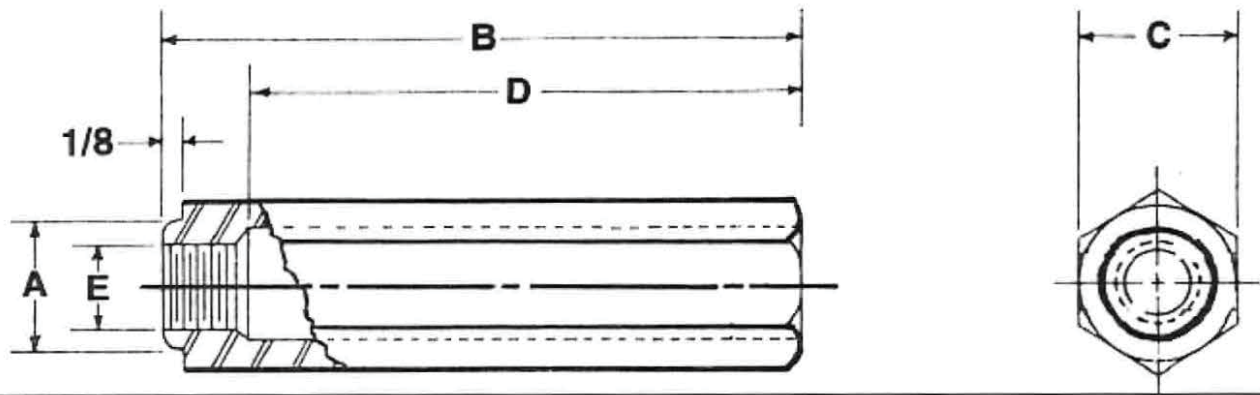

ORDER BY HANDLE SIZE NUMBER

GENERAL DIMENSIONS

	A	B	C	D	E
GB-9-1	47/64	4-1/8	13/16	3-3/4	3/8-16 UNC-2B
GB-9-2	63/64	4-7/8	1-1/8	4-1/4	1/2-20 UNF-2B

## SPLINE GAGE WASHERS

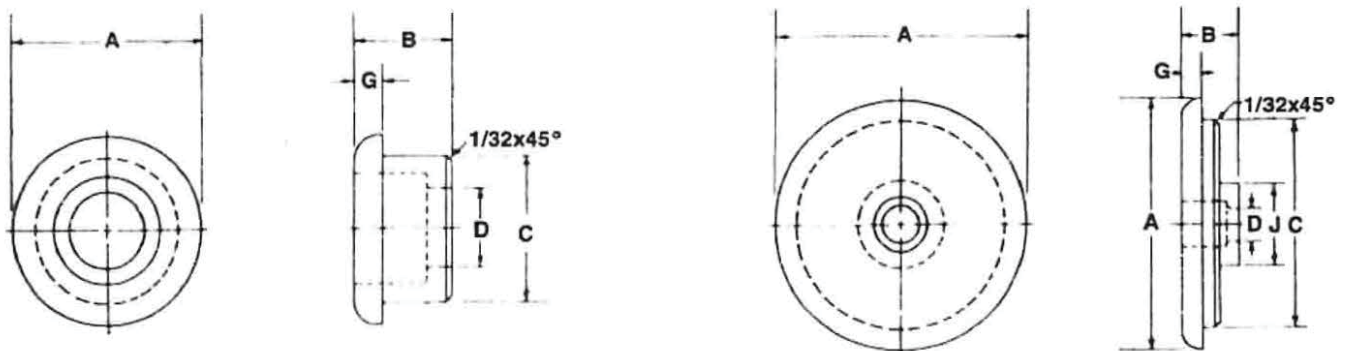

ORDER BY WASHER SIZE NUMBER

GENERAL DIMENSIONS

	A	B	C	D	G	J
GB-7-1	1	1/2	47/64	13/32	3/16	
GB-7-2	1-1/4	5/8	63/64	17/32	3/16	
GB-8-1	3	5/8	2-47/64	17/32	3/16	1-1/4
GB-8-2	4-3/8	5/8	3-63/64	17/32	3/16	1-1/4
GB-8-3	3	5/8	2-47/64	17/32	3/16	1-1/4
GB-8-4	4-3/8	5/8	3-63/64	17/32	3/16	1-1/4

## SPLINE GAGE BOLTS

ORDER BY BOLT SIZE NUMBER

GENERAL DIMENSIONS

	A	B	C	THREAD SIZE
GB-9-1-1	1-1/2	3/8	1-1/2	3/8 - 16 UNC-2A
GB-9-2-2	2-1/4	1/2	1-1/4	1/2 - 20 UNC-2A
GB-9-2-3	1-1/2	5/16	1-1/4	1/2 - 20 UNC-2A

To Order Contact: Gage Crib Worldwide Inc; Email: sales1@gagecrib.com