

# TRILOCK PLUG GAGE BLANKS

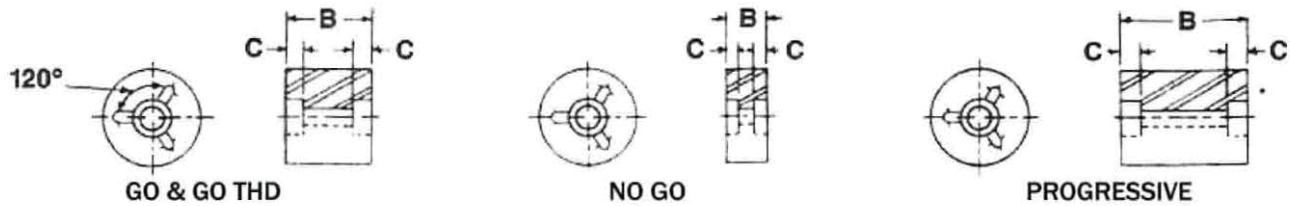

ORDER BY BLANK SIZE NUMBER	HANDLE SIZE NO.	GENERAL DIMENSIONS											
		DECIMAL RANGE		GO CYL		GO THD		GO THD		NO GO		PROG. Trunc - Thick	
		ABOVE	TO & INCL.	B	C	B	C	B	C	B	C	B	C
15/16	2-1/2	0.760	0.947	1-1/4	1/4	1	1/4	1	1/4	3/4	1/4	2-1/8	1/4
1-1/8	3-1/2	0.947	1.135	1-3/8	1/4	1-1/8	1/4	1	1/4	3/4	1/4	2-1/4	1/4
1-1/2	4-1/2	1.135	1.510	1-1/2	3/8	1-1/4	3/8	1	3/8	3/4	1/4	2-3/8	3/8
2	5-1/2	1.510	2.010	1-7/8	1/2	1-1/4	3/8			7/8	5/16	2-7/8	1/2
2-1/2	6	2.010	2.510	2	1/2	1-3/8	7/8			7/8	5/16	3	1/2

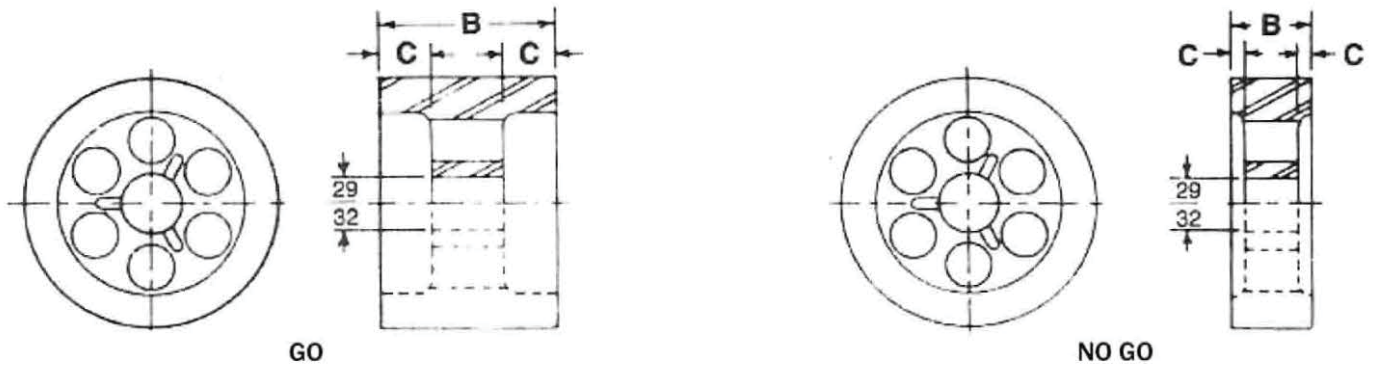

ORDER BY BLANK SIZE NUMBER	HANDLE SIZE NO.	GENERAL DIMENSIONS											
		DECIMAL RANGE		GO CYL		GO THD		NO GO		PROG. Trunc - Thick			
		ABOVE	TO & INCL.	B	C	B	C	B	C	B	C		
3	7	2.510	3.010	2	5/8							3-1/8	11/16
3-1/2	7	3.010	3.510										
4	7	3.510	4.010	2-1/8	11/16	1-1/2	3/8	1	1/8	3-1/4	3/4		
4-1/2	7	4.010	4.510										
5	7	4.510	5.010										
5-1/2	7	5.010	5.510										
6	7	5.510	6.010										
6-1/2	7	6.010	6.510										
7	7	6.510	7.010										
7-1/2	7	7.010	7.510										
8	7	7.510	8.010										

Trilock blanks available in 8620 Alloy Steel or O-6. Blanks can be turned to your finished size, plus grind stock, for an additional charge. Lightening holes are on 6" and larger.

To Order Contact: Gage Crib Worldwide Inc; Email: sales1@gagecrib.com