

ANNULAR DESIGN PLUG GAGE BLANKS

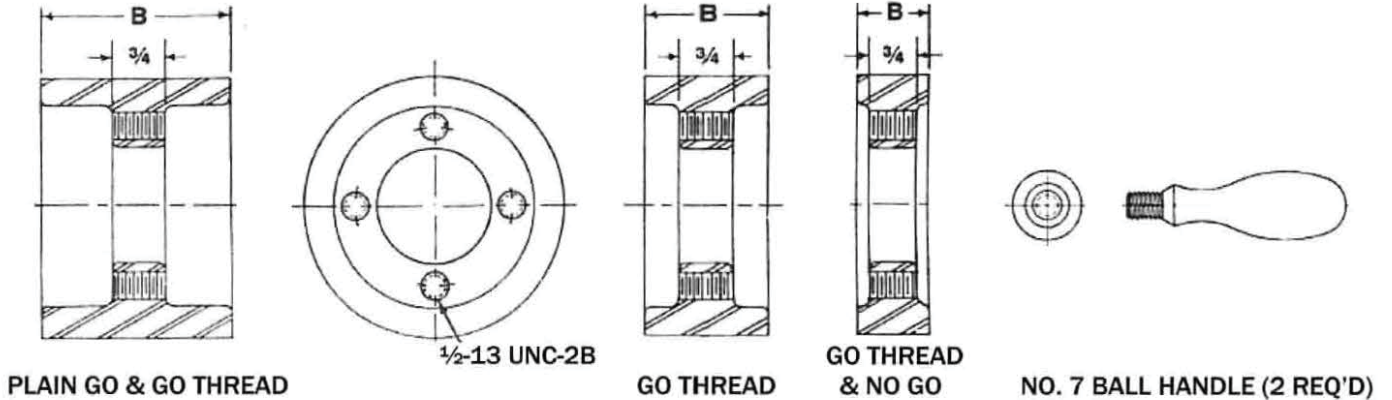

GENERAL DIMENSIONS

ORDER BY BLANK SIZE NUMBER	PLUG GAGE DECIMAL RANGE		PLAIN PLUG		THREAD PLUG			
			B		B			
			GO	NO GO	7 TPI & COASER	FINER THAN 7 TPI	16 TPI & FINER	ALL NO GO
	ABOVE	TO & INCL						
8-1/2	8.010	8.510	2-1/4	1	2-1/4	1-1/2	1	1
9	8.510	9.010						
9-1/2	9.010	9.510						
10	9.510	10.010						
10-1/2	10.010	10.510						
11	10.510	11.010						
11-1/2	11.010	11.510						
12	11.510	12.010						

Annular blanks available in Alloy Steel or Tool Steel. Blanks can be turned to your finished size, plus grind stock, for an additional charge.

To Order Contact:

Gage Crib Worldwide Inc.
6701 Old 28th St SE; Suite B
Grand Rapids MI 49546-6937

Email: sales1@gagecrib.com
Phone: 001.616.954.6581
Fax: 001.616.954.6583