

# THREAD RING GAGE BLANKS

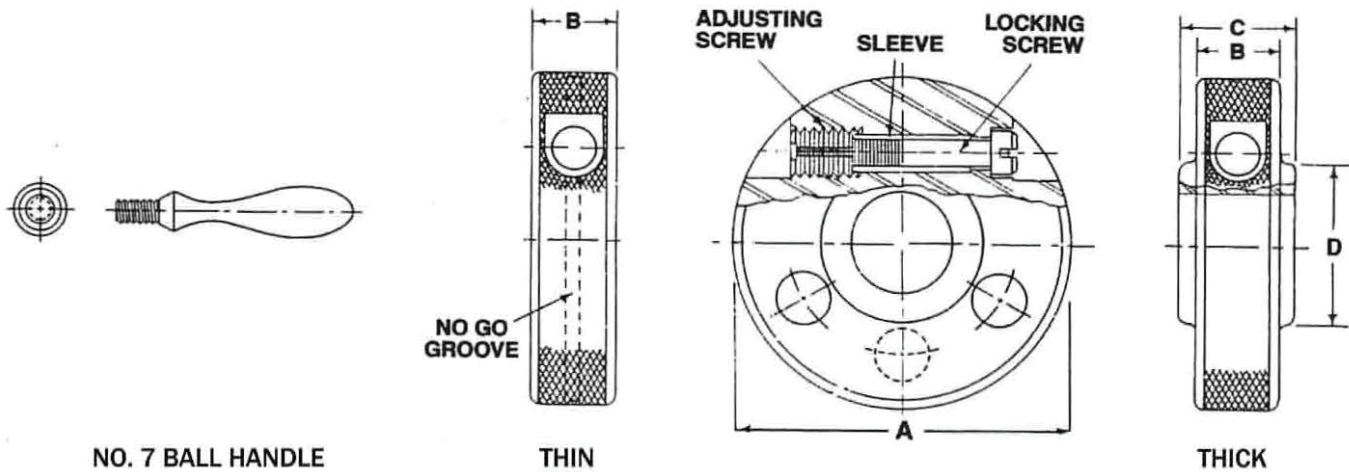

ORDER BY RING SIZE NUMBER	USE LOCK ASSY	RANGE		GENERAL DIMENSIONS				BALL HANDLE SIZE	BALL HANDLE HOLES	NOTE
		ABOVE	TO & INCL.	A	B	C	D			
1T	1	0.059	0.230	1	1/4					SPECIFY 1 OR 2 SPRING HOLES
2T	2	0.230	0.365	1-3/8	11/32					
3T	3	0.365	0.510	1-3/4	7/16					
4T	4	0.510	0.825	2-3/16	9/16	3/4	1-1/16			
5T	5	0.825	1.135	2-5/8	11/16	15/16	1-1/2			
6T	6	1.135	1.510	3-1/4	3/4	1-1/8	1-7/8			
7T		1.510	2.010	3-3/4	13/16	1-1/4	2-3/8			
8T	7	2.010	2.510	4-1/2	7/8	1-5/16	2-7/8			
9T		2.510	3.010	5	7/8	1-3/8	3-3/8			
10T		3.010	3.510	5-1/2	15/16	1-7/16	3-7/8			
11T	8	3.510	4.010	6-3/8	15/16	1-1/2	4-5/8			SPECIFY THIN OR THICK
12T		4.010	4.760	7-1/4			5-3/8			
13T		4.760	5.510	8-1/4			6-1/2			
14T		5.510	6.260	9-1/4			7-3/8			
15T		6.260	7.010	10-1/4			8-1/8			
16T		7.010	7.760	11-1/4	1		8-7/8	7	2	
17T		7.760	8.510	12-1/4			9-5/8			
18T		8.510	9.260	13-1/4			10-3/8			
19T		9.260	10.010	14-1/4			11-1/8			
20T		10.010	10.760	15-1/4			11-7/8			
21T		10.760	11.510	16-1/4			12-5/8			
22T		11.510	12.260	17-1/4			13-5/8			

**NOTE:** Rings larger than 22T quoted upon request

Thread Ring Blanks are made from Oil Hardening Tool Steel, not heat treated. Blanks can be bored to your specified size, allowing grind stock, for an additional charge.

To Order Contact: Gage Crib Worldwide Inc; Email: sales1@gagecrib.com